

RAILKING
READY-TO-RUN™
sets
THE COMPLETE SOLUTION

www.railking.com

Semi Convertible Brill Trolley

Operation Manual



RAILKING
By MICHÉLE LORAIN TRONC

Thank you for purchasing this RailKing product.
PLEASE READ BEFORE USE AND SAVE

Table of Contents

Setup Checklist	3
Getting Started	4
Assembling Real Trax	4
Installing the Lock-on	4
Connecting the Transformer	4
Lubricating the Engine	5
Remote Control	5
Basic Operation	6
Operation Buttons	6
Manual Volume Control	7
Proto-Sound 2.0 Operation	8
Activating Proto-Sound 2.0 Conventional Mode Features	8
Speed Control	11
Lock into a Direction	11
Reset to Factory Defaults	11
Automatic Sounds	11
Maintenance	12
Care of Remote Control	12
Lubrication and Greasing Instructions	12
Cleaning the Wheels, Tires and Track	13
Locomotive Light Bulb Replacement	13
Self-Charging Battery Back-Up	14
RailWare Interactive CDROM	15
Troubleshooting	16
Compatibility	17
Transformer Compatibility Chart	17
Additional Features with DCS Remote Control System	18
Exploded View Parts	19
Service and Warranty Information	

CAUTION: ELECTRICAL Y OPERATED PRODUCT:

Not recommended for children under 10 years of age. M.T.H. recommends adult supervision with children ages 10-16. As with all electric products, precautions should be observed during handling and use to reduce the risk of electric shock.

WARNING: When using electrical products, basic safety precautions should be observed, including the following: Read this manual thoroughly before using this device.

- M.T.H. recommends that all users and persons supervising use examine the hobby transformer and other electronic equipment periodically for conditions that may result in the risk of fire, electric shock, or injury to persons, such as damage to the primary cord, plug blades, housing, output jacks or other parts. In the event such a condition exists, the train set should not be used until properly repaired.
- Do not operate your layout unattended. Obstructed accessories or stalled trains may overheat, resulting in damage to your layout.
- This train set is intended for indoor use. Do not use if water is present. Serious injury or fatality may result.
- Do not operate the hobby transformer with damaged cord, plug, switches, buttons or case.
- The transformer was designed to operate on regular US household current (120 volt, 50-60 Hertz). Do not connect to any other source of power.
- To avoid the risk of electrical shock, do not disassemble the transformer unit. There are no user-serviceable parts inside. If the unit is damaged contact M.T.H. Service for instructions.
- The transformer is equipped with an internal circuit protector. If the circuit protector trips, unplug the power cord from the electrical wall outlet, check your layout for any short circuit. The circuit breaker will reset automatically when the shorts are removed from the circuit.
- Unplug the transformer from the electrical wall outlet when not in use.
- Do not use this transformer for other than its intended purpose.

Transformer Ratings:

Input: 120VAC, 60Hz Only, Output: 18VAC, 3.75A 78VA

Set Up Checklist

- Assemble RealTrax®
- Connect the transformer
- Lubricate the engine
- Place the engine on the track
- Position remote lock-on lens
- Apply power to run as described in the Basic Operation section of these instructions.

Set Includes

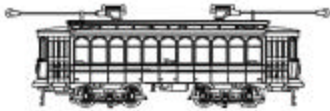

Brill Trolley with Proto-Sound@2.0



8-Pieces
O-31 Curve RealTrax



Track Clips



Remote Control



Lock-On



CD-Rom



Video

Tools Needed

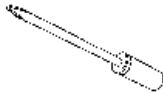

Philips Screwdriver



Pliers



Scissors



Cotton Swab or Rag



RailKing Maintenance Kit
Light Household Oil and Bearing Grease

You can obtain replacement parts and replacement instructions from the M.T.H. Parts Department

e-mail: parts@meth-railking.com

phone: 410-381-2580

mail: 7020 Columbia Gateway Drive, Columbia MD 21046-1532

Getting Started

Assembling RealTrax[®]

The quick connectors and built-in road bed allow you to setup RealTrax anywhere, including carpeted surfaces.

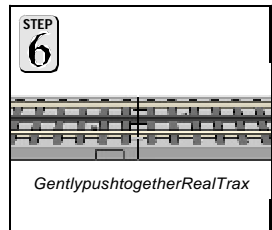
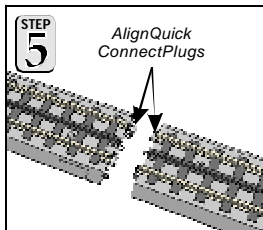
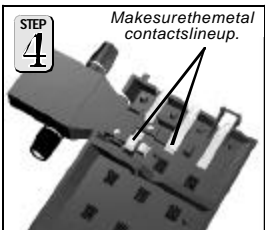
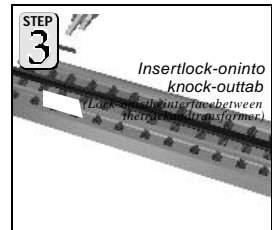
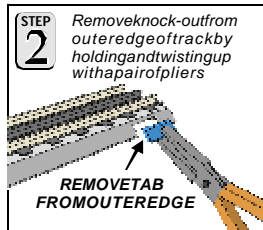
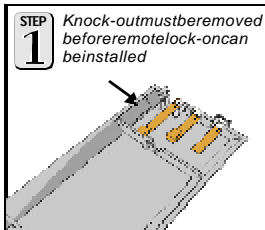

Connecting TrackClips

If you prefer not to screw your track to the table for a permanent layout, use the enclosed track clips on adjoining curved RealTrax sections to secure them in place.

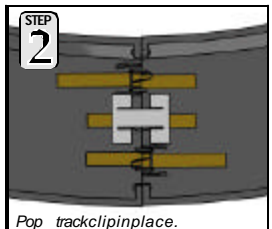
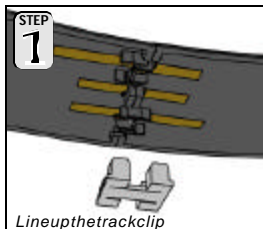

Connecting the Transformer

The 50-watt power supply included with this set provides an easy-to-use, safe power source for AC-powered trains and accessories.

- Plug the wire from the transformer into the remote lock-on's center port, then plug the transformer into the wall outlet.
- Unplug when not in use.

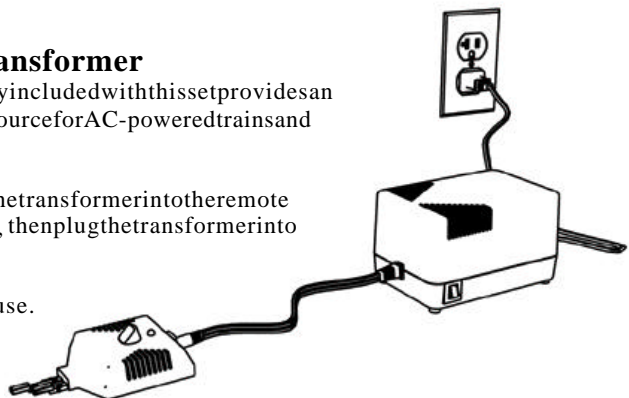

Lubricating the Engine

Lubricate all exposed moving parts before operating using a multi-purpose, plastic-compatible oil (available with M.T.H.'s Maintenance Kit, sold separately) or a light household oil. Follow the lubrication points.

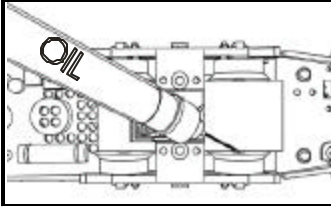

Lubricate Axles

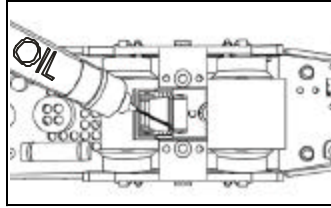

Lubricate Pick-Up Rollers
(Do Not Oil the Flat Part of
Pick-Up Rollers)

Remote Control

The remote and lock-on are designed for use with moderate power supplies such as the one included with this set. It is compatible with virtually any manufacturer's engines.

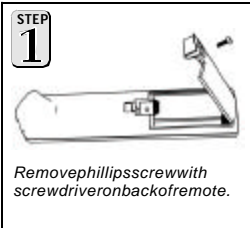

Remove phillips screw with screwdriver on back of remote.

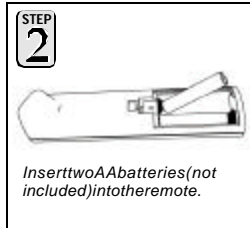

Insert two AA batteries (not included) into the remote.

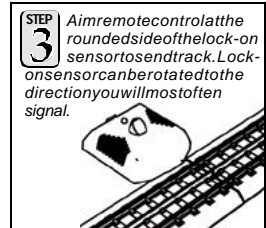

Aim remote control at the rounded side of the lock-on sensor to send track. Lock-on sensor can be rotated to the direction you will most often signal.

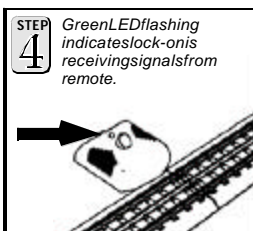

Green LED flashing indicates lock-on is receiving signals from remote.

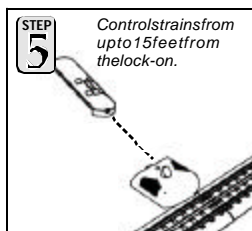

Control trains from up to 15 feet from the lock-on.

Note: The RailKing® Remote Control and Remote Lock-on will not operate engines equipped with pre-1997 versions of Proto-Sound® or with Proto-One,™ Proto-Plus,™ Proto-Deluxe,™ aftermarket systems.

Basic Operation

Operation Buttons

Throttle Up Throttle up the power to your track by pressing the top end of the Throttle Control Rocker Switch firmly for about 5 seconds, until the engine's headlight and lighted cars burn bright. Then put the engine in motion by firmly pressing the Direction button (hold it for approximately 1 second) on your remote once. If the engine does not begin to move as soon as you firmly press the Direction button, you may not have sent enough voltage to the track to make the train move. Press the throttle up for a few more seconds until the train begins to move.

To increase or decrease track voltage, and therefore train speed, press the throttle control rocker switch. Pressing the top end of the throttle will increase voltage and speed. Pressing the bottom end of the throttle will decrease voltage and speed.

The engine will maintain the speed you set after you release the throttle until you press it again to change the voltage and speed.

Bell - To sound the bell, firmly press and release the Bell button. To turn the bell off, press and release the Bell button again. The bell will continue to ring from the time you turn it on until you press and release the button again to turn it off.

Emergency Stop Press the Emergency Stop button and all train on the track controlled by the remote will stop until you reapply voltage. This is an easy way to shut down your trains at the end of a session or to stop suddenly if the train's path becomes obstructed.

CAUTION: *Do not mix old and new batteries. Do not mix alkaline, standard (carbon-zinc), or rechargeable (nickel-cadmium) batteries.*

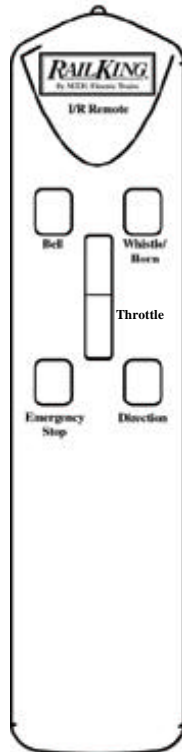

Horn/Whistle - Because this unit does not prototypically have a horn, pressing the horn button will sound a bell (different from the bell button bell). The bell will continue ringing as long as you hold the button.

Direction Your train is programmed to start in neutral. The train will always cycle neutral-forward-neutral-reverse with each press and release of the direction button. The engine is programmed to restart in neutral each time the track voltage is turned off for 25 seconds or more.

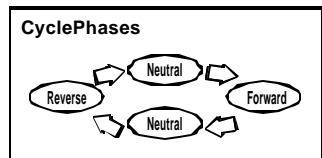

Manual Volume Control

To adjust the volume of all sounds made by this master volume control knob located under the increase the volume and counter-clockwise to

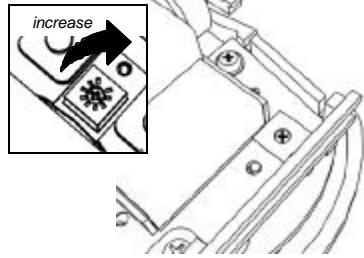

Proto-Sound 2.0 Operating Instructions

This manual contains the operating instructions for Proto-Sound 2.0 in conventional mode only. Instructions for accessing DCS command mode features accompany the DCS Remote Control System equipment.

Because Proto-Sound 2.0 is a all-new system developed by M. T. H.'s own research and development team, it operates differently from original Proto-Sound. Most Proto-Sound 2.0 features are automatically enabled, and Reset has been eliminated, so there is no need to program features as with original Proto-Sound. Although the new system is easier to operate than original Proto-Sound, you should read these instructions thoroughly before using Proto-Sound 2.0 features in order to prevent harm to yourself or your equipment.

Activating Proto-Sound 2.0 Conventional Mode Features:

Proto-Sound 2.0 features are activated by sequences of Bell and Horn button pushes described below. Please read the full description of each feature before using it. To use these buttons to activate features rather than to blow the horn or ring the bell, you should press the buttons firmly, but rapidly with a 1/2-second pause between button presses. You may need to practice your timing to make this work smoothly.

Timing Chart				
Press Horn	1/2 Sec. Pause	Press Bell	1/2 Sec. Pause	Press Bell
Short & Firm		Short & Firm		Short & Firm
Total Time Lapse: 1 1/2 Seconds				

Operating Modes

1. Manual Mode

Upon initial power application, the engine will start up in manual mode. The chart below lists the features available to the operator when in Manual Mode. Different features are available when operating in Learn and Auto Modes, which are described later.

Feature to Be Activated	Button Code:
Transit Announcement Sounds (TAS)	1 Bell (depress button approx. 2 secs.)
Speed Control On/Off	1 Horn, 2 Bells (from neutral only)
Lock into a Direction	1 Horn, 3 Bells
Reset to Factory Defaults (including default Auto Mode routes settings)	1 Horn, 5 Bells (from neutral only)

Transit Announcement Sounds (TAS):

Your Proto-Sound 2.0 trolley car is equipped with operator controlled Transit Announcement Sounds, hereafter known as TAS. These easy-to-use feature plays digitally reproduced transit announcements and platform actions sounds whenever you activate and stop your engine. No additional wires or modifications are needed on your layout to enjoy these amazing sound effects. These different sounds are heard each time you give a long bell button press. The entire TAS sequence is designed to simulate the arrival, disembarking, embarking, and departure of a transit stop. The sounds include the driver announcing the stop and the upcoming stop, passenger disembarking and embarking

sounds, drivertopassengerrequests,dooropeningsandclosingandgeneraltransitstop sounds. Afterthestationsoundshavefinished,theenginewillshiftbackintogearand,if thethrottlesissethighenough,willpullawayfromthestation.

- ToactivatetheTAS,pressandholdthebellbuttonforapproximately2seconds.
- IfyoudonotwishtostopatthestationthatisannouncedafteractivatingTAS,press andholdthebellbuttonagainwithoutthrottlingdownthetrain.

2. LearnMode

InLearnMode,theenginecanbeprogrammedwitheitheran"Out&Back"routeora "Loop"route.An"Out&Back"routebeginsatthe1ststation(asprogrammedbythe operator),stopsatintermediatestations,endsatthelaststation,thenreversesitsroute untilitreacheshe1ststation.A"Loop"routebeginsatthe1ststation(asprogrammedby theoperator),stopsatintermediatestations,endsatthelaststation,andthenbeginshe routeoveragainatthe1ststation.

ExampleofOutandBack:

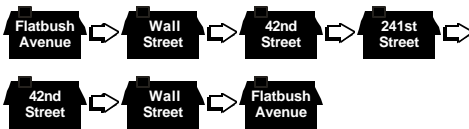

ExampleofLoop:

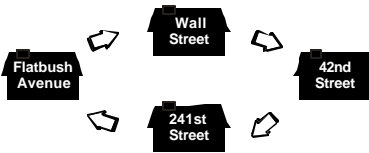

Toprogramstations:

1. RunninginForward,stoptheunitatthedesiredlocationforthefirststopbypressing thedirectionbutton.Note:ifyoustoptheenginewiththethrottlecontrol,youmustre- applypowersothattheenginegoesintoneutralanddoesnotshutdown.
2. EnterLearnModebypressingHorn-Bell-Bell-Bell-Bell.Thetrainwillthen announcethatyouhaveenteredLearnMode.
3. PressandholdtheBellbuttontoscrollthroughtheavailablestationsuntilyouhearthe onethatyouwouldliketobeyourfirststop. Releasebuttonquicklyassoonasyou haveheardtheddesiredstopname.
4. PressandholdtheHornbuttonuntिला"saved"responseconfirmsthatstation'slocation andnamearesavedinmemory.
5. ProceedtothenextstopbypressingtheDirectionbutton.
6. PresstheDirectionbuttontostopthetrainagainwhenyouhavereachedthenext desiredstationlocation.
7. UsingtheBellbutton,selectthenameofthestation,thensaveusingtheHornbutton.
8. Repeatsteps5-7untilyouarereadytoprogramthelaststopintheroute.
9. Themannerofsavingthelaststationintheroutedetermineswhethertheroutewillbe an"Out&Back"or"Loop"route.
 - "Out&Back":followsteps5-7tosavethelaststation.AfteryoupresstheHorn buttonandthesoundsystemplayshe"Saved"confirmation,pressstheHornbutton again. Another"Saved"confirmationwillplayandthecarwillexitLearnModeand enterManualMode.

- “Loop”: follow steps 5-7 to save the last station. Press the Direction button once to start the car in forward and stop the car **at the location of the first stop** by pressing the Direction button. Press the Bell button as many times as is necessary to hear the name of the first stop. Press the Horn button until the “Saved” confirmation is played. The car will then automatically exit Learn Mode and enter Manual Mode.

Notes:

- Always approach desired station stop location while running in Forward. Learn mode counts distance traveled, not actual physical locations. However, unlike an automobile's odometer, Proto-Sound 2.0 Learn Mode **does** erase distance when traveling in reverse. If you operate your car past the desired stop location, you may back it up to the desired stop location, however you must put the car in to forward and then neutral again before saving the stop name and location into memory.
- If you press the Direction button too soon (stop the car prior to the desired stop location), press the Direction button to continue to the next desired stop location in the forward direction.
- The factory defaults and your programmed settings both remain in memory after the engine is shut down, so there is no need to re-program your settings each time you run your car.

Auto Mode

When you have finished programming your stations in Learn the car will be in Manual Mode. Running in Forward, stop the car at the location of the first programmed station by pressing the Direction button. Press Bell-Horn-Horn to put the train into Auto Mode. Press the Direction button again to begin operation in Auto Mode. Because Auto Mode operation begins at the first stop, the next stop announced will be the second stop. The car will automatically travel, stopping and making announcements at each programmed stop, as long as it remains in auto mode.

Notes:

- The engine will always power up in Manual Mode.

Function Learn Mode	Button Code:
To Enter Learn Mode	1 Horn, 4 Bells
To Stop at Each Station	Direction
To Scroll through the Station Names	Bell (hold to scroll and release as soon as you hear the desired station name)
To Save Station	Horn (hold for “Saved” response)
Function Auto Mode	Button Code:
To Enter Auto Mode from Manual Mode	1 Bell, 2 Horn at the location of the first programmed station stop
To Begin Programmed Run	Direction
Function Manual Mode	Button Code:
To Enter Manual Mode from Auto Mode	1 Bell, 2 Horns

Speed Control:

M.T.H. engine equipped with Proto-Sound 2.0 has speed control capabilities that allow the engine to maintain a constant speed up and down grades and around curves, much like an automobile cruise control. You can add or drop cars on the run, and the engine will maintain the speed you set.

While the engine is programmed to start with the speed control feature activated, you can opt to turn it off. This means the engine's speed will fall as it labors up a hill and increase as it travels downward. It is also affected by the addition or releasing of cars while on the run.

To turn speed control on and off, put the engine in neutral, then quickly tap the transformer's Horn button one time then quickly tap the Bell button two times, allowing approximately 1/2 second to lapse between each quick button press. Two bell rings will indicate that the engine has made the change. Repeat the 1 horn, 2 bells code to return to the other condition. **You will want to do this during the initial neutral upon start-up if you ever couple this engine to another engine that is not equipped with speed control to avoid damaging the motors in either engine.** Each time you shut down the engine completely, it will automatically turn speed control on.

Note:

When speed control is turned off, the Proto-Sound 2.0 system will limit the volume in order to operate more smoothly at lower voltages. Full volume is restored upon reactivating speed control.

Lock into Direction:

You can lock your engine into a direction (forward, neutral, or reverse) so that it will not change directions. To do this, put the engine into the direction you want (or into neutral to lock it into neutral), run it at a very slow crawl (as slowly as it will move without halting), and quickly but firmly tap the Horn button once followed by three quick taps of the Bell button, allowing approximately 1/2 second to lapse between each quick button press. Two bell rings will indicate that the engine has made the change. The engine will not change direction (including going into neutral) until you repeat the 1 horn, 3 bells code to return the engine to its normal condition, even if the engine is kept without power for extended periods of time.

Reset to Factory Defaults:

To override the settings you currently have assigned to the engine and reset it to its factory defaults, while in Neutral quickly tap the Horn button quickly once, followed by five quick taps of the Bell button, allowing approximately 1/2 second to lapse between each quick button press. Two bell rings will indicate that the engine has made the change.

Automatic Sounds:

Certain Proto-Sound 2.0 sound effects automatically play in programmed conventional mode conditions:

- **Squealing Brakes** play any time the engine's speed decreases rapidly.
- **Platform Action Sounds** play at random intervals when the engine idles in neutral.
- **Engine Start-up and Shutdown** sounds play when the engine is initially powered on or is powered off for five seconds or more.

Maintenance

Care of the Remote Control

Your Rail King Remote Control System should offer years of trouble-free service. There are a few things you can do to ensure trouble-free operation:

- If your train responds inconsistently, replace old batteries with fresh ones. Do not mix old and new batteries.
- Remove batteries before storing for extended periods.
- Do not drop the remote. It can damage the delicate electronics inside.
- Any attempt by anyone other than an authorized M.T.H. repair person to open and repair the handheld transmitter or lock-on may result in damage and the loss of warranty protection.
-

Lubrication Instructions

The engines should be oiled and greased in order to run properly.

Regularly lubricate all side rods and linkage components and pick-up rollers to prevent squeaking. Use light household oil, such as that found in M.T.H.'s maintenance kit. Do not overoil. Use only a drop or two on each pivot point.

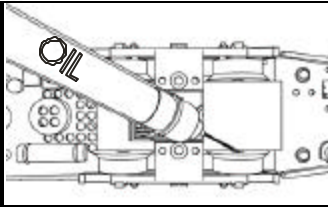

Lubricate Axles

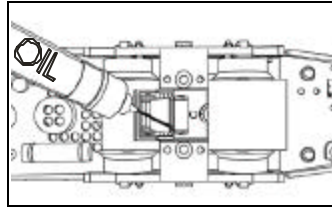

Lubricate Pick-Up Rollers
(Do Not Oil the Flat Part of
Pick-Up Rollers)

Greasing Instructions

The locomotive's internal gearing was greased at the factory. Grease engine every 50 hours of use or once a year. Use a lithium based grease and follow the greasing instructions.

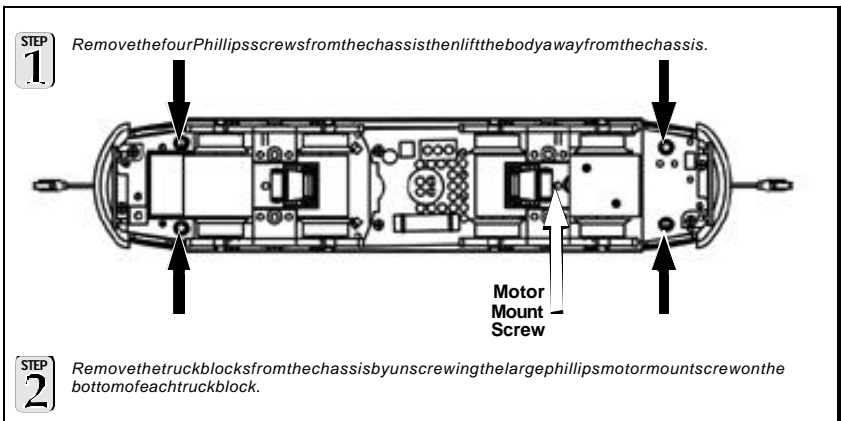

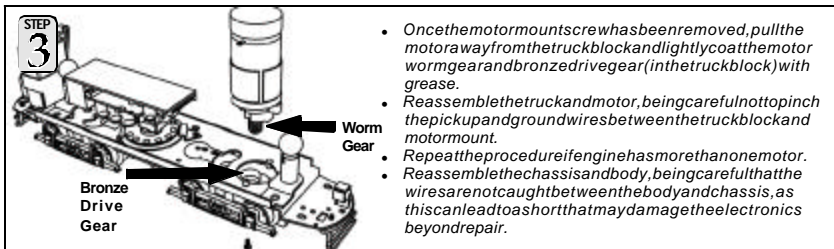

Cleaning the Wheels, Tires and Track

Periodically check the locomotive wheels and pickups for dirt and buildup, which can cause poor electrical contact and traction and prematurely wear out the neoprene traction tires. Wheels and tires can be cleaned using denatured (not rubbing) alcohol applied with a cotton swab.



To clean the track, use Rail King Track Cleaning Fluid and a clean rag or denatured (not rubbing) alcohol. Unplug the transformer and wipe the rails of the track, turning the rag frequently to ensure that you are using clean cloth on the rails. Because the manufacturing process leaves a coating on Real Trax center rail, you should clean the rails after the first 30 minutes of use (you may notice an electrical smell during initial use as the coating wears off; this is normal). Thereafter, keep an eye on the track and clean it when it gets dirty to ensure good electrical contact and to lengthen the life of the tires.

Trolley Light Bulb Replacement

Follow the removal instructions found in the “Lubrication and Greasing” section of this booklet. (page 12)

Interior lights: Twist and lift out the bulbs as shown.

Destination Board Lights: Unplug the two-pin connector holding the shell to the chassis. Pull the LED bulbs from their housing and remove from the clip holding the wire to the ceiling. Replace entire LED unit.

Headlights: Pull the LED bulb from its housing, trace the wire back to its two-pin connector and unplug. Replace the entire unit.

Note: When changing lights, please be sure to tuck all wires back into their protective clips or bundle to prevent chafing on movable parts.

You can obtain replacement bulbs directly from the M.T.H. Parts Department.

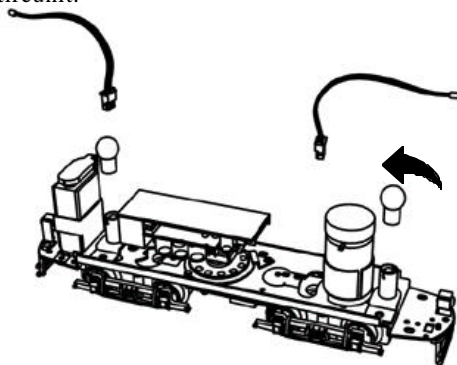

Self-Charging Battery Back-Up

The special NiCad 7-cell 8.4v self-charging battery recharges continuously during train operation and should last for up to five years. The battery is a dry battery that should not leak or cause any damage to your engine. **Depending upon when your engine was built, it may need to be charged right out of the box.** If engine sounds seem distorted or garbled at low voltages or becomes silent when power from the transformer is turned off, test the battery to determine whether it should be recharged or replaced.

- **Test:** Put the engine in neutral and leave the track voltage at 10-12 volts (high enough for the lights to shine brightly and the engine to move steadily) for 15 minutes.
- **Recharge:** If the sounds are improved at the end of the 15-minute test charge, the battery charge has run down and can be recharged. There are a number of ways you can do this:
 - Leave the engine in neutral with track voltage at 10-12 volts for 6-7 hours so the battery can fully recharge (if your engine has a smoke unit, be sure it is turned off).
 - Use M.T.H.'s battery recharger (sold separately) that plugs into a wall outlet and a special port under the tender to recharge the battery overnight without leaving it on the track.

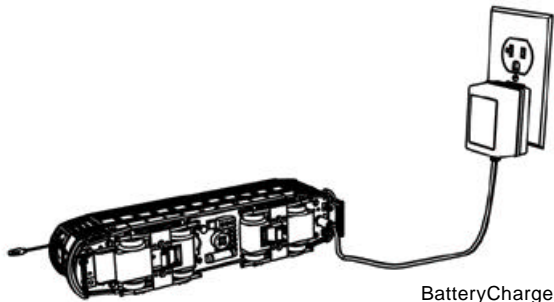

Battery Charger
Item No. 50-1005

- **Replace:** If the sounds are not improved at the end of the 15-minute test charge, it is time to replace the battery. Available through M.T.H. Parts. A standard 9v alkaline battery can be substituted until your replacement arrives, but since alkaline batteries cannot be recharged, it will eventually wear down. **Do NOT use a 6-cell 7.2v battery.**

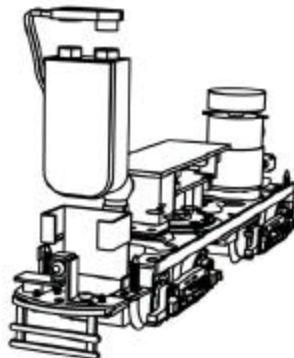
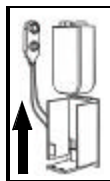

Quick-Start Video

The included VHS Quick-Start video demonstrates the start-up and basic operation of this set as well as other information about model railroading. You may find it helpful to view the video before operating this set.

RailWare Interactive CD ROM

M.T.H. provides a free RailWare CD ROM in each Ready-To-Run set. It is full of helpful information on M.T.H. product history, track planning software, a dealer finder, and information and video clips on Loco-Sound and Proto-Sound 2.0. Follow the directions below to use the CD ROM.

Minimum System Requirements: Pentium 100, 16MB RAM, Windows 95 or later, CD ROM drive, Sound Card, display properties set to greater than 256 colors. The CD will not work on a Mac OS unless you run Virtual PC.

Running RR-Track Software

You may run the RR-Track software directly off of the CD ROM or you may install the software to your hard drive.

1. On the Desktop, click on the icon that says My Computer.
2. Find your CD ROM drive.
3. With the M.T.H. CD ROM in the drive, double click on the icon for the CD ROM drive.
4. Find the folder on the CD ROM entitled INSTALLATION.
5. Choose the folder inside entitled RRTRAXSETUP.
6. Run the file in that folder called SETUP.EXE and follow the directions it provides.

The program may ask you for a registration code. If it does type in "M.T.H." and it will run.

Additional track libraries can be obtained directly from RR-Track. See their website for more information www.rtrack.com.

Installing Adobe Acrobat Software

To read some of the electronic documents included on the CD ROM, you will need to install the Adobe Acrobat Reader® if it is not already on your computer. To install the software:

1. On the Desktop, click on the icon that says My Computer.
2. Find your CD ROM drive.
3. With the M.T.H. CD ROM in the drive, double click on the icon for the CD ROM drive.
4. Find the folder on the CD ROM entitled INSTALLATION.
5. Choose the folder inside entitled ACROBATREADER.

*If you are running Windows 95, 98 or NT choose the folder 32BIT. Run the file AR32E301.EXE and follow the directions it provides.

If you have problems you cannot resolve by using these directions, contact custserv@mth-railking.com or call 410-381-2580 for further help.

Troubleshooting Proto-Sound® 2.0 Problems

Although Proto-Sound 2.0 has been designed and engineered for ease of use, you may have some questions during initial operation. The following tables should answer most questions. If your problem cannot be resolved with this table, contact M. T. H. for assistance (e-mail: service@mt-h-railking.com; telephone: 410-381-2580; fax: 410-423-0009; mail: 7020 Columbia Gateway Drive, Columbia MD 21046-1532).

StartingUp	Remedy
When I press the horn button, the bell comes on instead.	That is normal for this model.
I can't get any sound to play when I press the horn button.	You may be pressing the button too quickly to trigger the bell. Try pressing the horn button more slowly, taking approximately one full second to fully depress the button.
Horn	Remedy
When I press the horn button, the bell comes on instead.	That is normal for this model.
I can't get any sound to play when I press the horn button.	You may be pressing the button too quickly to trigger the bell. Try pressing the horn button more slowly, taking approximately one full second to fully depress the button.
Bell	Remedy
When I press the horn button, the bell sounds.	Reverse the transformer leads.
I can't get the bell to ring when I press the bell button.	You may be pressing the button too quickly. Try pressing the horn button more slowly, taking approximately one full second to fully depress the button.
The bell won't work on a separate bell button.	Check the wiring of these separate button.
When I press the bell button, I get a station stop announcement, not the bell.	You are holding the bell button too long. Press it for only about one second to trigger the bell.
Coupler	Remedy
When I try to fire the coupler, TAS starts.	You are waiting too long between horn button presses.
The Proto-Coupler won't let the engine uncouple on the fly.	Try lubricating the coupler knuckle and drive with dry graphite lubricant.
The coupler does not fire or stay coupled.	The coupler needs to be cleaned. Wipe with denatured alcohol (not rubbing alcohol) and let dry.
Platform Action Sounds	Remedy
Sometimes the Platform Action Sounds don't play.	Platform Action Sounds play only in neutral at random intervals.
Lock-out	Remedy
I can't get the engine to run after I power up the transformer. It sits still with the diesel and compressor sounds running.	The engine is locked into the neutral position. Follow the procedure in the "Lock into a Direction" section.
The engine won't lock into forward, neutral, or reverse.	Engine speed must be below 10 scale mph (approx. 10 volts or less in conventional mode).
Volume	Remedy
The sound seems distorted, especially when the horn or bell is activated.	Proto-Sound 2.0 volume is set too high. Turn the volume control knob on the bottom of the chassis counter-clockwise to reduce the volume.
No Sound	Volume is set too low, adjust volume control knob on the bottom of the chassis clockwise to increase the volume or check connector to speaker.
Battery	Remedy
The engine will not leave the initial neutral setting.	Check to be sure the battery is installed and fully charged. See the "Self-Charging Battery Back-Up" section.
I get no sounds when the engine shifts between directions.	The battery may be dead or need to be recharged. See the "Self-Charging Battery Back-Up" section.
After I turn off my transformer, my engine continues to make sounds before quitting.	Proto-Sound 2.0 is designed to continue to sound for a few seconds after power to the track has been shut off to allow for a more realistic shut-down.
TAS	Remedy
The TAS sounds occasionally repeat themselves.	Proto-Sound 2.0 has a built-in random number generator that randomly selects each sound clip to play. Because there are a limited number of sound clips available in each TAS sequence, it is probable that some of these sound clips will be repeated from time to time.

Compatibility

While this Ready-To-Run set is equipped with everything you need to operate it, the design allows flexibility. The train will operate on any traditional O-31 or larger O Gauge track system, including the ScaleTrax™ included with this set or traditional tubular track. It is also compatible with most standard AC transformers, including the hobby transformer packaged with your set.

Transformer Compatibility and Wiring Chart

Note that many of the operational commands described in these instructions require a bell button, so if you are using a transformer other than the one included in this set and your transformer does not have its own bell button, you should consider adding one to get the full benefit of the system.

Transformer Model	Center Rail	Outside Rail	Min/Max. Voltage	Power Rating	Transformer Type
MTHZ-500	Red Terminal	Black Terminal	0-18v	50-Watt	Electronic
MTHZ-750	Red Terminal	Black Terminal	0-21v	75-Watt	Electronic
MTHZ-4000	Red Terminal	Black Terminal	0-22v	390-Watt	Electronic
Lionel1032	U	A	5-16v	90-Watt	Standard
Lionel1032M	U	A	5-16v	90-Watt	Standard
Lionel1033	U	A	5-16v	90-Watt	Standard
Lionel1043	U	A	5-16v	90-Watt	Standard
Lionel1043M	U	A	5-16v	90-Watt	Standard
Lionel1044	U	A	5-16v	90-Watt	Standard
Lionel1053	U	A	8-17v	60-Watt	Standard
Lionel1063	U	A	8-17v	60-Watt	Standard
All-Trol	Left Terminal	Right Terminal	0-24v	300-Watt	Electronic
Dallee Hostler	Left Terminal	Right Terminal			Electronic
Lionel LW	A	U	8-18v	75-Watt	Standard
Lionel KW	A or B	U	6-20v	190-Watt	Standard
Lionel MW	Outside Track Terminal	Inside Track Terminal	5-16v	50V.A.	Electronic
Lionel RS-1	Red Terminal	Black Terminal	0-18v	50V.A.	Electronic
Lionel RW	U	A	9-19v	110-Watt	Standard
Lionel SW	U	A	Unknown	130-Watt	Standard
Lionel TW	U	A	8-18v	175-Watt	Standard
Lionel ZW	A, B, C or D	U	8-20v	275-Watt	Standard
Lionel Post-War Celebration Series ZW	A, B, C or D	Common	0-20v	135/190 Watt	Electronic

Additional Features Accessible with the DCS Remote Control System: (additional equipment required)

While conventional mode operation of a Proto-Sound 2.0 engine yields wonderfully realistic sound and several train control features, command mode operation allows the user to access a world of command functions never before accessible to O Gauge railroaders. With the addition of the DCS Remote Control System (including a DCS remote handheld and Track Interface Unit) users gain many advanced features, including:

- DCS Proto-Speed Control - Establishes desired locomotive speeds in scale miles per hour increments via a thumb wheel control and allows operator to set maximum speed and acceleration/deceleration rates
- ProtoSmoke[®] Variable Output Control - Control show much smoke each engine outputs and matchessmoke to locomotive speed
- Locomotive Lighting Control - Controls locomotive headlights, marker and interior lights, beacon lights, ditch lights, and MARS lights
- Emergency Stop - Single button push stops all Proto-Sound 2.0 trains but does not turn off the power
- One Touch Global Mute/UnMute - Single button mutes or unmutes all DCS-controlled locomotives' user-defined actions, including sound, lights, and smoke
- Proto-Dispatch Operation - Public Address-like feature allows user to speak through locomotive speaker during operation
- Proto-Cast - Allows user to play audio recording through locomotive speaker during operation
- Proto-Doppler Sound Effects Setup - Users can configure locomotive for Doppler Operation, including setting distance points for Doppler start, repeat, and stop modes
- Independent Volume Control of Engine Sounds, Bell, Horn & Whistle for each Locomotive
- Control up to 50 different DCS-Equipped Locomotives at one time with multiple TIUs
- Proto-Effects[™] Setup - Users can select individual Proto-Effects[™] operation to be active or inactive, including cab chatter, train wreck sounds, couplers sounds, and wheel clickety-clack sounds
- Direction Control Setup - Users can set initial individual start-up direction (start in forward or reverse) for double-heading operations
- Locomotive Consist Set-up - Users can determine locomotive values for consist make-ups, allowing multiple locomotives belonging to a consist to operate together
- Query Locomotive Information - Users can query locomotive programming to learn locomotive address and engine data information, including scale miles traveled
- User Can Query, Set and Operate Track and Accessory Interface Units for Programming Digital Command Operations for up to 250 Accessories and 250 Individual Switches
- User Can Script, Record and Playback Train Routes

Operating instructions for all DCS Command features will accompany the DCS remote control equipment.

Brill Trolley Locomotive Shell Parts

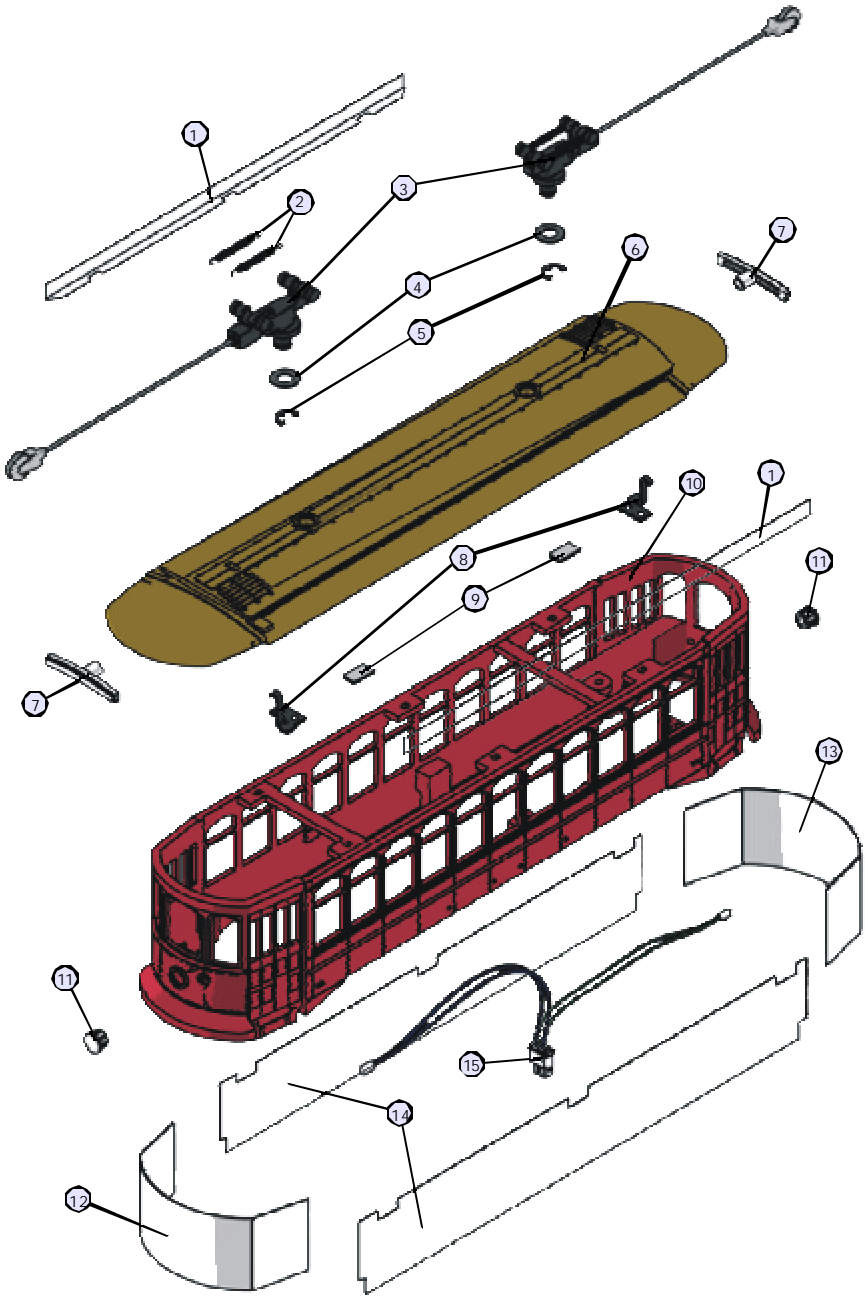

Brill Trolley Locomotive Shell Parts

Name and Number	Part #
1.) Lens(clear)(187.0mmlong)	FA-3200009
2.) Spring(black) (3.0x16.5mm)(w/0.3mmthickwire)	IE-0000053
3.) Trolley pole(black&nickel) (completew/springs)	FF-3200027
4.) Washer(clear) (5.0x9.0x0.2mm)	ID-0000086
5.) E-clip(black)(3.0x8.0x0.5mm)	IF-0000002
6.) Roof(gray) (NewYorkTransit)(#1144) Roof(red) (Christmas)(#2001) Roof(black) (PhiladelphiaTransit)(#27)	FF-3200050
7.) Lens(blackw/clearletters) (145TH&LenoxAve.)(NewYorkTransit)(#1144)	FA-3200016
Lens(blackw/whiteletters) (NorthPole)(Christmas)(#2001)	FA-3200017
Lens(blackw/clearletters) (SharonHill)(PhiladelphiaTransit)(#27)	FA-3200018
8.) Clip(black) (forholdingdowntrolley pole)	FF-3200031
9.) Wirestrap(white) (plastic)(clip)	IH-0000289
10.) Shell(red,cream,gray) (NewYorkTransit)(#1144)	FF-3200053
Shell(red,green,white) (Christmas)(#2001)	FF-3200054
Shell(red,cream,silver,black) (PhiladelphiaTransit)(#27)	FF-3200055
11.) Lens(clear) (headlight/back-up light)	FA-3200012
12.) Lens(tintedw/figure) (doorlenshasnotaboneachside)	FA-3200015
13.) Lens(tintedw/figure) (doorlenshasonetaboneachside)	FA-3200013
14.) Lens(tintedw/figures)	FA-3200014
15.) Bulbs(clear)(2)(6v) (170.0mmlongwiresw/blackmale2pinplug) (grainofwheat)	CC-0000047

Brill Trolley Locomotive Chassis Parts

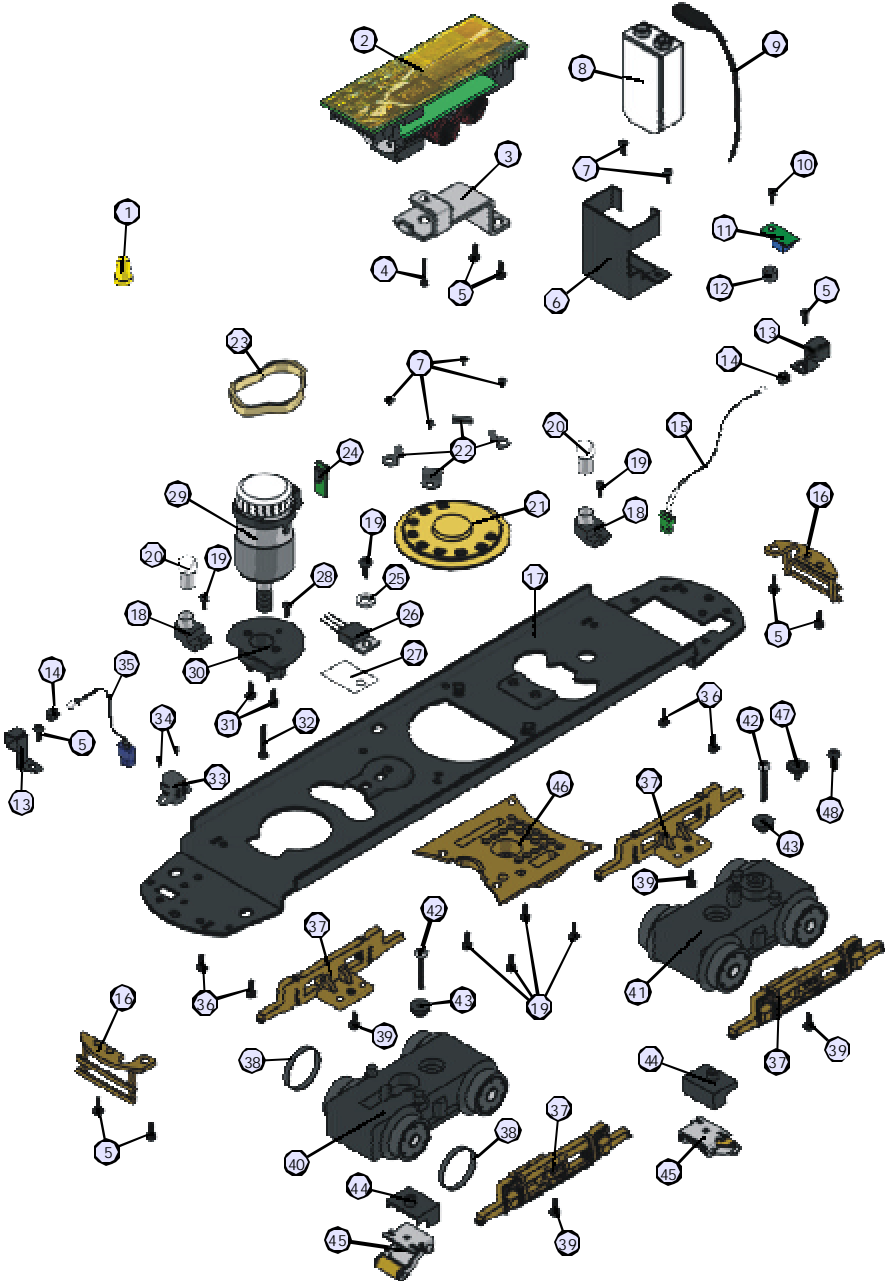

Brill Trolley Locomotive Chassis Parts

Name and Number	Part #
1.) Wirenut(yellow)	BI-4500003
2.) Boards(Proto-Sound® 2.0)	AE-0000004
3.) Bracket(Aluminum) (15.0x47.0mm)(11.5mmstep) (forProto-Sound® 2.0boards)	IH-0000290
4.) Screw (6/32x12.0mm)(roundhead)	IA-0000103
5.) Screw (M3x4.0mm)(roundhead)	IA-0000010
6.) Bracket(black) (metal)(battery)	IH-0000219
7.) Screw (M3x3.0mm)(roundhead)	IA-0000296
8.) Battery	BG-4000001
9.) Batteryleads (145.0mmlongwiresw/smallblackmale2pinplug) (150.0mmlongwiresw/batterychargerjack)	BC-0000120
10.) Screw (M3x8.0mm)(roundhead)	IA-0000035
11.) Volumepot(small) (bluepotmountedongreenPCboard)	BI-0000040
12.) Spacer(black) (plastic)(3.0x6.0x4.0mm)	ID-0000071
13.) Bracket(black)(lightbracket) (8.2x14.0mm)(15.6mm&6.8mmsteps)(metal)	IH-0000291
14.) Grommet(black) (cupped)(rubber)	IH-0000144
15.) Bulb(clear)(6v) (90.0mmlongwiresw/greenmale2pinplug) (grainofwheat)(reverselight)	CF-0000012
16.) Grill(black) (NewYorkTransit)(#1144)(PhiladelphiaTransit)(#27) Grill(red)	FF-3200056
(Christmas)(#2001)	FF-3200057
17.) Chassis(black)(metal) (forProto-Sound® 2.0)	GB-3200003
18.) Bracket(black) (15.0x22.0mmplasticbasew/9.2mmstep) (forbayonetbulb)	IH-0000267
19.) Screw (M3x6.0mm)(roundhead)	IA-0000016
20.) Bulb(clear) (6v)(smallglobe)(bayonetbase)	CG-0000024

21.) Speaker (UnisonU4516BC1, 16ohms,0.7watt)	BF-0000013
22.) Bracket(brass) (speaker)(9.0x9.5mm)(0.7mmthick)(3.0mmstep)	IH-0000271
23.) Rubberband	BI-4500004
24.) Tachboard	AG-0000033
25.) Insulatorwasher(white) (3.0x6.0x3.0mm)	ID-0000025
26.) Voltageregulator(LM2937ET)	AG-0000032
27.) Insulator(clear) (13.0x16.0x0.1mm)(singlehole)	ID-0000024
28.) Screw (4/40x4.0mm)(roundhead)	IA-0000021
29.) Motor(RS-365SH) (7.9x18.5mmwormgearw/10.0mmlongthreads) (9.5x30.0mmwhitetaperedflywheelw/blackstripes) (w/tachboardmount)	BE-0000100
30.) Motormount(black)	BI-0000041
31.) Screw(yellowZink) (M2.5x6.0mm)(roundhead)(w/lockwasher)	IA-0000089
32.) Screw (M3x10.0mm)(roundhead)(w/lockwasher)	IA-0000155
33.) Batterychargerjack(black) (complete)	BG-0000001
34.) Screw (M2x4.0mm)(roundhead)	IA-0000058
35.) Bulb(clear)(6v) (90.0mmlongwiresw/bluemale2pinplug) (grainofwheat)(headlight)	CA-0000045
36.) Screw (M3x16.0mm)(washerhead)(self-drillingthreads)	IA-0000025
37.) Truckside(black) (NewYorkTransit)(#1144)(PhiladelphiaTransit)(#27) Truckside(green) (Christmas)(#2001)	DB-0000007 DB-0000008
38.) Tractiontire(black)(rubber)	DE-0000014
39.) Screw (4/40x6.0mm)(flathead)	IA-0000038
40.) Truck(black) (2axle)(powered)(spokedwheels)	DA-0000009
41.) Truck(black) (2axle)(non-powered)(spokedwheels)	DA-0000010
42.) Screw(nickel) (M2.5x12.0mm)(roundhead)	IA-0000160
43.) Insulator(black) (pick-up)(round)(top)	BD-0000046
44.) Insulator(black) (pick-up)(bottom)	BD-0000003

Service & Warranty Information

How to Get Service Under the Terms of the Limited One-Year Warranty

For warranty repair, follow the instructions below to obtain warranty service.

- First, e-mail, write, call or fax an Authorized M.T.H. Service Center in your area or M.T.H. Electric Trains to obtain Repair Authorization. You can find the list of Authorized Service Centers on the M.T.H. website, www.mth-railking.com. Otherwise, contact M.T.H. (e-mail: service@mth-railking.com; 7020 Columbia Gateway Drive, Columbia, MD 21046; tel: 410-381-2580; fax: 410-423-0009), stating when the item was purchased and describing the problem. If you contact M.T.H., you will be given a return authorization number to assure that your merchandise will be properly handled upon its receipt.
- **CAUTION:** Make sure the product is packed in its original factory packaging including its foam and plastic wrapping material also to prevent damage to the merchandise. The shipment must be prepaid and we recommend that it be insured. ***A cover letter including your name, address, daytime phone number, e-mail address (if available), Return Authorization number, a copy of your sales receipt and a full description of the problem must be included to facilitate the repairs. Please include the description regardless of whether you discussed the problem with a service technician when contacting the Service Center M.T.H. for your Return Authorization.***
- Please make sure you have followed the instructions carefully before returning any merchandise for service.

Limited One-Year Warranty

All M.T.H. products purchased from an Authorized M.T.H. Train Merchant are covered by this warranty.

See our website at www.mth-railking.com or call 1-888-640-3700 to identify an Authorized M.T.H. Train Merchant near you.

M.T.H. products are warranted for one year from the date of purchase against defects in material or workmanship, excluding light bulbs, pick-up rollers and traction tires. We will repair or replace (at our option) the defective part without charge for the parts or labor, if the item is returned to an Authorized M.T.H. Service Center or M.T.H. Electric Trains within one year of the original date of purchase. This warranty does not cover damages caused by improper care, handling, or use. Transportation costs incurred by the customer are not covered under this warranty.

Items sent for repair must be accompanied by a return authorization number, a description of the problem, and **a copy of the original sales receipt from an Authorized M.T.H. Train Merchant**, which gives the date of purchase. If you are sending the item to M.T.H., call 410-381-2580, fax 410-423-0009, or e-mail the Service Department at service@mth-railking.com to obtain a return authorization number. If you are sending this product to an Authorized Service Center, contact that Center for their return authorization.

This warranty gives you specific legal rights, and you may have other rights that vary from state to state.

Service Department
M.T.H. Electric Trains
7020 Columbia Gateway Drive
Columbia, Maryland 21046-1532



www.railking.com